

ASSEMBLY INSTRUCTION FOR AIRCRAFTPLUGS® DC 28VDC

1. IDENTIFY THE CORRECT CONDUCTOR SIZE USED AND MATCH THE PROPER AIRCRAFTPLUGS® ASSEMBLY. EACH AIRCRAFTPLUGS® KIT INCLUDES CRIMP BARRELS FOR SPECIFIC CONDUCTOR SIZES.
2. IF REPAIRING AN EXCISTING ASSEMBLY, REMOVE THE DAMAGED PLUG FROM THE CABLE ASSEMBLY BY CUTTING OF THE CONDUCTORS FROM THE REAR OF THE DAMAGED PLUGS. ENDS OF CUT OFF CONDUCTORS MUST BE EVEN.
3. STRIP OUTER JACKETS OF POWER CONDUCTORS 45 MM (1 3/4") AND INNER JACKET 30MM (1 1/4"). STRIP OFF 30MM (1 1/4") FROM ONE PIECE JACKET.
4. CRIMP BARRELS ON THE WIRE USING AN AIRCRAFTPLUGS® HYDRAULIC TOOL AND MS90485 DIE. MAKE 2 CRIMPS APPROX.12MM (1/2") APART AND 5MM (1/4") FROM THE END OF THE BARREL.
5. DO NOT DAMAGE THE CONDUCTOR STRANDING.
6. COVER BOTH CRIMP JOINTS, THE EXPOSED CONDUCTOR BETWEEN THE INSULATION AND THE CRIMP BARREL AND 1/2" TO 3/4" OF THE CONDUCTOR INSTALATION WITH GLASS CLOTH ELECTRICAL TAPE, OR HEATED SHRINK AVAILABLE FROM AIRCRAFTPLUGS®.
7. INSTALL THE 4/0 AWG SEALING GROMMET ONTO THE 4/0 AWG CONDUCTORS. TEMPORARILY POSITION IT ABOUT 15CM (6") BACK FROM THE ENDS OF THE CRIMP BARRELS.
8. MOUNT PLUG IN VISE JUST BEHIND THE CONTACT AREA. THREAD A PULL ROD INTO EACH LUG TO CLEAN OUT THREAD.
9. FOR THE FOLLOWING STEPS WE RECOMMEND THE USE OF ASSEMBLY TOOL KIT AIRCRAFTPLUGS®. THE KIT CONTAINS THREADED PULL RODS, AND A DRIVE SOCKET FITTED TO A HED ROD PERMITTING THE USE OF A TORQUE WRENCH.
10. INSECT THREADED PULL-RODS THROUGH CONTROL CONTACTS IN FRONT OF THE PLUG AND SREW THEM INTO APPROPRIATE BARRELS. PULL UP BARRELS UNTIL THEY ARE SEATED IN THEIR SOCKETS AT REAR OF THE CONTACTS. WHERE NO CONDUCTORS REMOVE THE PULL-RODS, INSECT SOCKET HEAD SREWS AND HAND TIGHTEN.
11. TIGHTEN THE SCREW TO 5NM (45 INCH/LBS) FOR POWER CONTACTS THEN TIGHTEN E AND F CONTACTS (5NM - 45 INCH/LBS).
12. PERFORM A CONTINUITY CHECK TO ASSURE ALL CONDUCTORS ARE CORRECTLY CONNECTED TO THEIR RESPECTIVE CONTACTS. RETIGHTEN AS REQUIRED
13. CHECK ALL CONNECTIONS FOR CONTINUITY. MAKE SURE ALL CABLES ARE CORRECTLY WIRED TO THEIR RESPECTIVE CONTACTS.
14. BAND CABLE 30 CM (12") FROM REAR OF THE PLUG AND EVERY 60 CM (24") THEREAFTER.
15. PERIODICALLY CHECK THE TORQUE ON CONTACT SCREWS AND CLEAN CONTACTS USING A BRUSH AND A SMALL AMOUNT OF NEAT'S OIL OR PETROLEUM JELLY, AND WIPE CLEAN. IF RUBBER IS WORN AWAY EXPOSING CONTACTS REPLACE HEAD IMMEDIATELY.

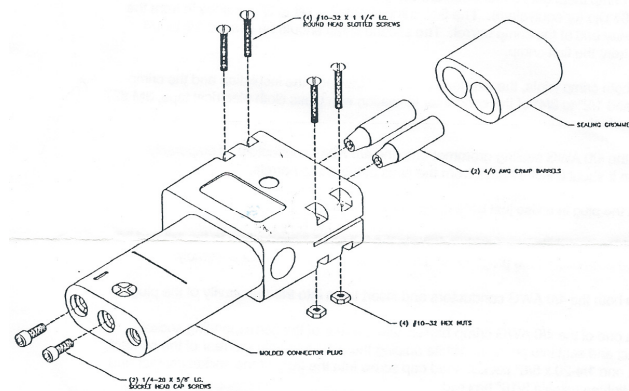

Aircraftplugs
 Kruisboommolenstraat 7 office 9 - 8800 Roeselare - - Belgium
 ☎ +32-491.152.980 - FAX : +32-51.77.99.19
 E-mail : info@aircraftplugs.com
www.aircraftplugs.com